

the sensor people

rotoScan ROD4... plus
Laser scanner



en 05-2015/08 50127551
We reserve the right to
make technical changes

1	General information	6
1.1	Explanation of symbols	6
1.2	Declaration of conformity	6
2	Safety	7
2.1	Intended use	7
2.2	Foreseeable misuse	8
2.3	Competent persons	8
2.4	Exemption of liability	8
2.5	Laser safety notices	9
2.6	Restrictions with regards to use	9
3	Description	10
3.1	Technical overview	10
3.1.1	Object measurement	11
3.1.2	Object detection (only ROD4 plus and ROD4-08 plus)	11
3.2	Operating principle	12
3.2.1	Measurement function	13
3.2.2	Switching function (only ROD4 plus and ROD4-08 plus)	13
3.3	Special features of the ROD4...plus	14
3.4	Application examples	15
3.4.1	Object measurement:	15
3.4.2	Object detection (only ROD4 plus and ROD4-08 plus)	16
4	Mounting	19
5	Electrical connection	20
5.1	Connecting the rotoScan ROD4...plus	20
5.1.1	Connection functions Y1 to Y4	21
5.1.2	Connector assignments for connection Y1	22
5.1.3	Connector assignments for connection Y2 (Ethernet)	22
5.1.4	Connector assignments for connection Y3 (service)	23
5.1.5	Connector assignments for connection Y4 (RS 232/RS 422)	24
5.2	Functions of connection Y1	25
5.2.1	Input circuit	25
5.2.2	Output circuit	27
5.2.3	Restart	28
5.3	Functions of connection Y2	28
5.3.1	Y2 default settings	28
5.4	Functions of connection Y3	29
5.4.1	Y3 default settings	29
5.5	Functions of connection Y4	29
5.5.1	Y4 default settings	29
5.6	Connection	30
5.6.1	Electrical supply	30

5.6.2	Button for restarting (only ROD4 plus and ROD4-08 plus)	30
5.7	Integration in the control system (only ROD4 plus and ROD4-08 plus).....	31
5.7.1	Connection example 1: without detection field pair switch	31
5.7.2	Connection example 2: with detection field pair switch	32
6	Start-up	33
6.1	Hardware and software requirements	33
6.2	Device configuration	33
6.2.1	Configuring measurement applications with RODplussoft	34
6.2.2	Selecting the measurement data protocol.....	34
6.2.3	Defining detection fields with RODsoft (only ROD4 plus and ROD4-08 plus)35	
6.3	Screwing down and aligning the device.....	36
6.4	Switch on the device	36
7	Testing and maintenance.....	37
7.1	Test.....	37
7.2	Cleaning.....	37
8	Delivery contents and accessories	38
8.1	Type overview	38
8.2	Accessories.....	38
8.2.1	Pin assignments KB-014S-...-14.....	39
8.2.2	KB-ROD4plus... pin assignments	39
8.2.3	Pin assignment KB ET-...-SA-RJ45 (crossover cable)	39
8.2.4	Pin assignments KB ET-...-SA	40
8.2.5	Pin assignments K-D M12A-8P-.....	40
8.2.6	BT ROD4 mounting system.....	41
9	Technical data	42
9.1	Object measurement.....	42
9.2	Detection field data (only ROD4 plus and ROD4-08 plus).....	42
9.3	Electrical data	43
9.4	Software	44
9.5	Optical data	44
9.6	Environmental data	48
9.7	Dimensioned drawing ROD4...plus	49
10	Status messages, errors and error rectification	50
10.1	Ethernet status indicator	50
10.2	ROD4...plus status indicator	51
10.2.1	Status displays	52
10.3	Diagnostic codes and causes	52
11	Appendix.....	56
11.1	Terms and abbreviations ROD4...plus	56

Table 3.1:	Device types.....	10
Figure 3.1:	Detection fields.....	11
Figure 3.2:	Working range and angular resolution	12
Figure 3.3:	Operating principle	12
Figure 3.4:	Application example - gripping system.....	15
Figure 3.5:	Application example - gantry crane	15
Figure 3.6:	Application example - dimension measurement.....	16
Figure 3.7:	Application example - service robot	16
Figure 3.8:	Application example - automatic parking garage	17
Figure 3.9:	Application example - high-bay warehouse.....	17
Figure 5.1:	Connecting the rotoScan ROD4...plus.....	20
Table 5.1:	Connections of the ROD4...plus – Y1 to Y4	21
Table 5.2:	Pin assignments for connection Y1	22
Table 5.3:	Pin assignments for connection Y2	22
Table 5.4:	Connection M12 to M12 (1:1)	23
Table 5.5:	Connection M12 to RJ45 (1:1)	23
Table 5.6:	Pin assignments for connection Y3.....	23
Table 5.7:	Pin assignments for connection Y4.....	24
Figure 5.2:	Inputs of interface Y1	25
Figure 5.3:	Example: Detection field pair switch for a DTS application	26
Figure 5.4:	Outputs of interface X1.....	27
Figure 5.5:	Connection example without detection field pair switch	31
Figure 5.6:	Connection example with detection field pair switch.....	32
Figure 6.1:	User interface of the RODsoft configuration software	35
Figure 8.1:	Dimensioned drawing BT ROD4	41
Table 9.1:	Technical data - object measurement	42
Table 9.2:	Technical data - detection fields.....	42
Table 9.3:	Technical data - electrical data.....	44
Table 9.4:	Technical data - software	44
Table 9.5:	Technical data - optical data	45
Figure 9.1:	Object size/diffuse reflection as a function of distance for the ROD4... plus	46
Figure 9.2:	Typical beam dimensions with the ROD4...plus	47
Table 9.6:	Technical data - environmental data	48
Figure 9.3:	Dimensioned drawing ROD4...plus.....	49
Figure 10.1:	Ethernet status indicator.....	50
Figure 10.2:	ROD4...plus status indicator	51
Table 10.1:	Status displays on the rotoScan ROD4...plus.....	52
Table 10.2:	ROD4...plus - Diagnostic codes and causes	53

1 General information

1.1 Explanation of symbols

The symbols used in this technical description are explained below.



Attention!

This symbol precedes text messages which must strictly be observed. Failure to comply with this information results in injuries to persons or damage to the equipment.



Attention Laser!

This symbol warns of possible danger caused by hazardous laser radiation.

The laser used in the ROD4...plus is a laser device of laser safety class 1 acc. to DIN EN 60825-1. Observe the legal and local regulations applicable to the operation of laser units.



Notice!

This symbol indicates text passages containing important information.

1.2 Declaration of conformity

The rotoScan ROD4... plus distance sensors have been manufactured observing current European standards and guidelines.



Notice!

The corresponding declaration of conformity can be requested from the manufacturer.

The manufacturer of the product, Leuze electronic GmbH + Co. KG in D-73277 Owen/Teck, possesses a certified quality assurance system in accordance with ISO 9001.



2 Safety

This sensor was developed, manufactured and tested in line with the applicable safety standards. It corresponds to the state of the art.

2.1 Intended use

The ROD4... plus is an optical, two-dimensional measuring distance sensor.

Areas of application

The sensors of the ROD4... plus series are especially designed for the following areas of application:

- Height/position detection
- Overshoot detection (e.g. in fully automatic parking systems)
- Buffering protection (e.g. for telfpher lines)
- Contour measurement
- Packet measurement / volume measurement



CAUTION

Observe intended use!

- ⚡ Only operate the device in accordance with its intended use. The protection of personnel and the device cannot be guaranteed if the device is operated in a manner not complying with its intended use.
Leuze electronic GmbH + Co. KG is not liable for damages caused by improper use.
- ⚡ Read the technical description before commissioning the device. Knowledge of this technical description is an element of proper use.

NOTICE

Comply with conditions and regulations!

- ⚡ Observe the locally applicable legal regulations and the rules of the employer's liability insurance association.

OPERATION NOTICE IN ACCORDANCE WITH UL CERTIFICATION:

CAUTION – Use of controls or adjustments or performance of procedures other than those specified herein may result in hazardous light exposure.

ATTENTION ! Si d'autres dispositifs d'alignement que ceux préconisés ici sont utilisés ou s'il est procédé autrement qu'indiqué, cela peut entraîner une exposition à des rayonnements et un danger pour les personnes.



Attention

For UL applications, use is only permitted in Class 2 circuits in accordance with the NEC (National Electric Code).

2.2 Foreseeable misuse

Any use other than that defined under "Intended use" or which goes beyond that use is considered improper use.

In particular, use of the device is not permitted in the following cases:

- Rooms with explosive atmospheres
- Circuits relevant to safety
- For medical purposes

NOTICE

Do not modify or otherwise interfere with the device.

- ↳ Do not carry out modifications or otherwise interfere with the device. The device must not be tampered with and must not be changed in any way. The device must not be opened. There are no user-serviceable parts inside. Repairs must only be performed by Leuze electronic GmbH + Co. KG.

2.3 Competent persons

Connection, mounting, commissioning and adjustment of the device must only be carried out by competent persons.

Prerequisites for competent persons:

- They have a suitable technical education.
- They are familiar with the rules and regulations for occupational safety and safety at work.
- They are familiar with the technical description of the device.
- They have been instructed by the responsible person on the mounting and operation of the device.

Certified electricians

Electrical work must be carried out by a certified electrician.

Due to their technical training, knowledge and experience as well as their familiarity with relevant standards and regulations, certified electricians are able to perform work on electrical systems and independently detect possible dangers.

In Germany, certified electricians must fulfill the requirements of accident-prevention regulations BGV A3 (e.g. electrician foreman). In other countries, there are respective regulations that must be observed.

2.4 Exemption of liability

Leuze electronic GmbH + Co. KG is not liable in the following cases:

- The device is not being used properly.
- Reasonably foreseeable misuse is not taken into account.
- Mounting and electrical connection are not properly performed.
- Changes (e.g., constructional) are made to the device.

2.5 Laser safety notices



ATTENTION, INVISIBLE LASER RADIATION – LASER CLASS 1

The device fulfills the EN 60825-1:2007 safety regulations for a product in **laser class 1** as well as the U.S. 21 CFR 1040.10 regulations with deviations corresponding to "Laser Notice No. 50" from June 24th, 2007.

- ⚠ Observe the applicable statutory and local laser protection regulations.
- ⚠ The device must not be tampered with and must not be changed in any way.
There are no user-serviceable parts inside the device.
Repairs must only be performed by Leuze electronic GmbH + Co. KG.

2.6 Restrictions with regards to use

- Glass, highly reflective materials such as mirrors (luminosity coefficient > 10,000%) as well as objects which do not reflect any light back to the sensor could falsify the measurement value. Additional notices can be found in chapter 9.5.
- Do not expose the ROD4... plus to flying sparks (e.g. welding sparks); the front cover, among other parts of the system, will be damaged.
- Vapours, smoke, dust and all particles visible in the air could affect the measurement values and cause the semiconductor outputs to switch off.
- Avoid large temperature fluctuations.
- If a protective housing is provided for the sensor, the detection must not occur through additional window material (plastic, glass, etc.).
- Physical contact with the front cover of the sensor and the six diffused-light windows is to be avoided.

3 Description

3.1 Technical overview

Designation	Design	Part no.
ROD4 plus	For object detection / object measurement, scanning rate 25scans/s	50106481
ROD4-08 plus	For object detection / object measurement, scanning rate 25scans/s, with heating, dust-insensitive	50106480
ROD4-50 plus	For object measurement, scanning rate 50scans/s	50113226
ROD4-56 plus	For object measurement, scanning rate 50scans/s, with heating	50129795
ROD4-58 plus	For object measurement, scanning rate 50scans/s with heating, dust-insensitive	50113225

Table 3.1: Device types

The ROD4...plus is an optical, two-dimensional measuring distance sensor. It could also be referred to as an optical, area radar unit. The device periodically transmits light pulses within an scanning angle of 190° via a rotating deflector unit.

If the pulses are incident upon objects or obstacles, the light is reflected and then received and analysed by the ROD4...plus. From the propagation time of the radiated light and the current angle of the deflector unit, the ROD4...plus unit calculates the exact coordinates of the object.

These data can be used by the ROD4...plus for 2 different areas of application:

1. **Object measurement**
An angular resolution of 0.36° allows the distance to objects to be measured with an accuracy of 5mm within the measurement range drawn in figure 3.1.
2. **Object detection (only ROD4 plus and ROD4-08 plus)**
Detection field contours can be defined within the detection fields drawn in figure 3.1. If an object is located within these detection field contours, this is reported by the ROD4...plus to the configurable switching outputs.

For **object measurement** tasks, the device is configured using the **RODplussoft** software.

If the ROD4...plus is to be used for **object detection**, device configuration is performed with **RODsoft**.

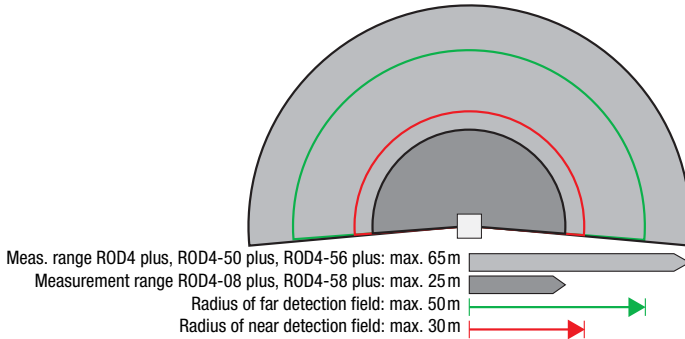

Figure 3.1: Detection fields

The ROD4 plus and ROD4-08 plus can be used both on vehicles (mobile object detection for vehicles) as well as in stationary applications on systems and machines (object detection/measurement).

The long-range and contactless measurement principle makes the ROD4...plus unit a universally applicable measuring system.

3.1.1 Object measurement

In measurement operation, the ROD4...plus transfers all measured distance data to a primary control or to a PC. An object contour can be calculated from the measurement data. The **RODplussoft** software can be used to configure the Ethernet interface (Y2) and the serial interface (Y4) for outputting the measurement data. Furthermore, the type of protocol used for measurement data transfer can be set.

In addition, preprocessing of the measurement data can be performed in the ROD4...plus:

- The data quantity can be reduced in order to match the quantity to the possible transmission speed
- The measurement data can be filtered on the basis of user-defined specifications

For further information on measurement data preparation, please refer to the **RODplussoft** manual.

3.1.2 Object detection (only ROD4 plus and ROD4-08 plus)

For object detection, detection fields are defined with the **RODsoft** software.

If an object or obstacle is located within these detection fields, a stop function is executed.

The ROD4 plus and ROD4-08 plus can detect objects with diameters greater than 20mm at a distance of up to 4.0m, even if the surface of the given object is dark. Larger objects are detected in the **far** detection field at a distance of up to 50m.

3.2 Operating principle

The working range of the ROD4...plus (190°) is divided into 0.36° angular segments (corresponds to 529 measurement values).

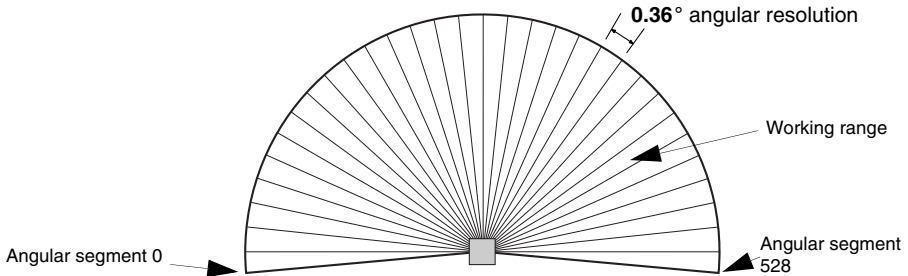

Figure 3.2: Working range and angular resolution

Bundled light pulses are generated by a laser diode with coupled transmission optics. These light pulses are reflected by a rotating mirror in such a way that a light pulse is emitted every 40ms in all angular segments (scanning rate: 25scans/s or 50scans/s). If the light pulse is incident upon an object, it is reflected and subsequently detected and analysed by the ROD4...plus.

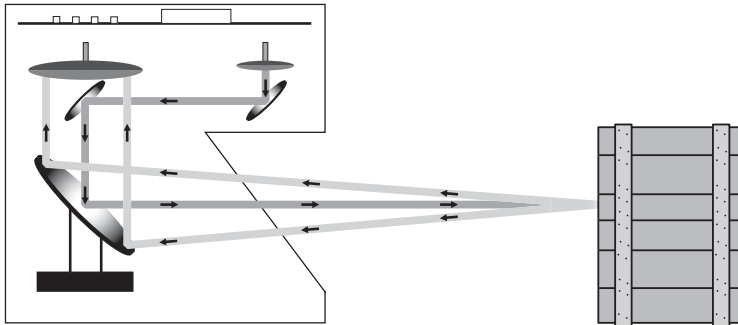

Figure 3.3: Operating principle

The ROD4...plus works on the principle of pulse propagation time measurement. The light pulse propagation time is a direct measurement of the distance to the object.

The measurement values are transferred via interfaces Y2 and Y4 as 16bit data (2 bytes). One scan over the working range returns 529 measurement values (from angle -5.04° to angle $+185.04^\circ$ with 0.36° angular resolution). Thus, each individual measurement value corresponds to an angular segment of 0.36° . The measurement values are sequentially numbered from segment 0 (-5.04°) to segment 528 ($+185.04^\circ$), see figure 3.2.

Reference measurement

A reference measurement cyclically controls the measurement function. The following functions are checked on each rotation of the mirror by means of a test object located inside of the device:

- optical systems (e.g. transmitter and receiver)
- hardware, software, etc.

Window monitoring

A total of six light axes monitor the degree of soiling of the window. During this procedure, the results are compared with two reference sensors. Moreover, these reference sensors are used for temperature compensation and ageing monitoring.

3.2.1 Measurement function

You can configure the measurement functions of the ROD4...plus yourself with the supplied **RODplussoft** software.

You can define the measurement mode (continuous/individual measurement), define measurement segments (start/stop angle, angular resolution), as well as define the type of measurement data transfer (in polar or cartesian coordinates) and pre-process and filter the measurement results in the ROD4...plus.

3.2.2 Switching function (only ROD4 plus and ROD4-08 plus)

You can configure the switching functions of the ROD4 plus and ROD4-08 plus yourself with the supplied **RODsoft** software. In addition to the device configuration, the software can also be used to define detection field pairs, to adapt them to the given application and to save the same in the ROD4 plus or ROD4-08 plus.

Four reversible detection field pairs make possible an optimal adaptation to the applications. A detection field pair is considered to be the combination of both a **near** and **far** detection field. The **near** and **far** detection fields are represented by different colours in the **RODsoft** configuration software: **near** = red, **far** = green.

The image of the surroundings generated during the scan process is compared with the specified detection field contours. If an object violates a detection field for a least one scan (40ms), a corresponding, user-specific reaction is triggered.

3.3 Special features of the ROD4...plus

- **ROD4 plus and ROD4-08 plus** for **object detection / object measurement**, scanning rate **25 scans/s**
- **ROD4-50 plus, ROD4-56 plus and ROD4-58 plus** for **object measurement**, scanning rate **50 scans/s**
- Working range up to 190°
- Small construction size (W x D x H: 141 mm x 168mm x 167 mm)
- Low weight (2.3kg)
- Low current consumption
- Two interfaces for measurement data transfer:
 - Ethernet at socket Y2
 - RS 232/RS 422 at connector Y4
- Easy-to-use **RODsoft** and **RODplussoft** configuration software (object detection with ROD4 plus and ROD4-08 plus)
- Measurement data processing:
 - X,Y coordinate transformation
 - Area configuration
 - Measurement data filtering: minimum and maximum values
 - Online commands
- ROD4 plus and ROD4-08 plus:
 - Four freely programmable **near** detection fields (up to maximum 30m)
 - Four freely programmable **far** detection fields (up to maximum 50m)

3.4 Application examples

The following examples can be considered typical areas of application for the ROD4...plus.

3.4.1 Object measurement:

Gripping system

Dimension and position measurement for gripping operations

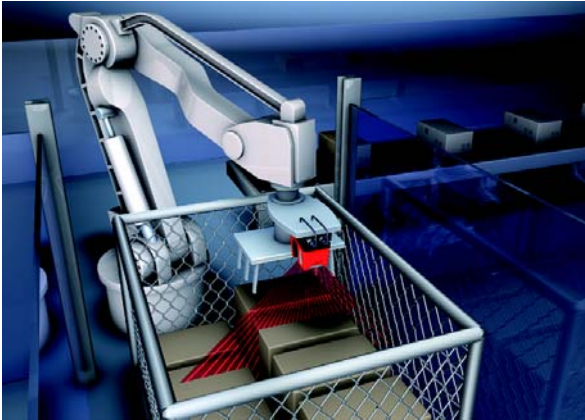

Figure 3.4: Application example - gripping system

Gantry crane

ROD4...plus for positioning a gantry crane

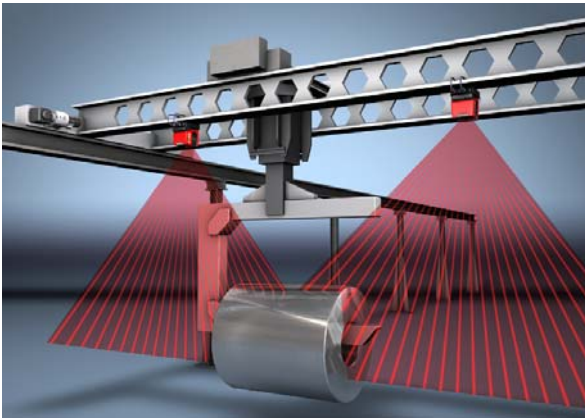

Figure 3.5: Application example - gantry crane

Pallet measurement

Dimension measurement in materials handling



Figure 3.6: Application example - dimension measurement

3.4.2 Object detection (only ROD4 plus and ROD4-08 plus)

Driverless transportation system

ROD4...plus as the "eye" of a service robot



Figure 3.7: Application example - service robot

Automatic parking garage

Overshoot and dimension detection of cars to prevent damage to the car



Figure 3.8: Application example - automatic parking garage

High-bay warehouse

Overshoot detection for collision prevention with high-bay storage devices

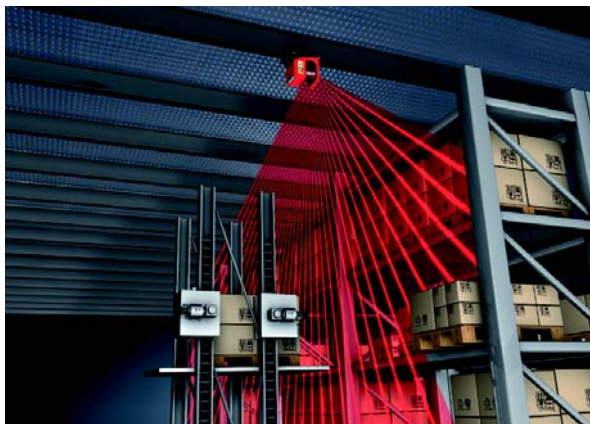

Figure 3.9: Application example - high-bay warehouse

Other applications

- Buffing protection (e.g. for telpher lines)
- Overshoot detection (e.g. in fully automatic parking systems)
- Detection / counting of persons
- Room security / façade monitoring
- Access control
- Contour measurement
- Packet measurement / volume measurement
- etc.

4 Mounting

Mount the ROD4...plus so that the area being monitored is within the measurement range of the device.



Attention!

Because of the optical scanning principle, only objects with good reflective properties are detected directly in front of the sensor window.

Physical damage to the sensor (e.g. due to collision or climbing on) should be prevented by using a protective enclosure. If using an enclosure, the entire front cover of the device must, however, remain unobstructed.

In order for the ROD4...plus to function optimally, it must be mounted in a favourable position. You should make every effort to observe the following points:

- Position the ROD4...plus such that it has maximum protection.
- The mounting location and the electrical supply should be located as close as possible to one another.
- The ROD4...plus is to be mounted so that the area being monitored is within the measurement range of the device.
- The mounting position of the ROD4... plus must offer protection from humidity, soiling, as well as temperatures below 0°C (ROD4 plus, ROD4-50 plus) or -20°C (ROD4-08 plus, ROD4-56 plus, ROD4-58 plus) and above 50°C.
- The mounting location is to be selected such that the possibilities for mechanical damage are minimised. Exposed locations are to be equipped with additional protective guards or loop guards.
- Reinforcements, enclosures, mounting alcoves and other machine elements must not result in an obstruction in the field of vision.
- Retro-reflectors or very reflective surfaces, such as certain metals or ceramics, are to be avoided near the detection fields and at the height of the scanning plane as these may result in measurement errors.
- To ensure a constant detection height at every point in the measurement range, the ROD4...plus, and thus the beam plane, is to be mounted parallel to the reference plane.
- If the ROD4...plus is used without start disable or start test with automatic start/restart, a start warning (optical/acoustic) is to be provided.
- The ROD4...plus must not be used as a climbing aid. If there is a risk of this, a suitable, inclined (45°) protector is to be mounted.

The device dimensions and the reference of the scanning plane to the device edges can be found in the dimensioned drawing (see figure 9.3 on page 47). Here, the zero point for the distance measurement is the axis of rotation of the rotating mirror (**a** in figure 9.3). Mounting system BT ROD4...plus, see chapter 8.2.6.



Notice!

Under certain circumstances, a larger measurement inaccuracy may occur with strongly reflective backgrounds (e.g. retro-reflectors).

5 Electrical connection

5.1 Connecting the rotoScan ROD4...plus

To **configure** the ROD4...plus, connect the control cable (KB-014-5000-14, plug Y1) to the power supply and the interface cable (KB-ROD4 plus-..., socket Y3) to the PC or laptop. Furthermore, interface Y2 for transferring the process data should be connected to the PC or the same network as the PC.



Notice!

To **configure the measurement function with RODplussoft**, Y2 or Y4 may be connected instead of Y3. For the initial configuration of the interfaces, it is, however, recommended that Y3 be connected.

To **transfer the process data with RODplussoft**, Y2 or Y4 may be selected. Following the initial configuration, subsequent configuration can be performed in parallel with process data transfer **via a single interface (Y2 or Y4)**.

To configure the detection function with **RODsoft**, it is absolutely necessary to connect Y3.

Before commissioning the system, please check the pin assignments, the wiring, the supply voltage and the safeguarding. In spite of the robust housing and fittings of the ROD4...plus, which include various internal safety mechanisms, damages resulting from misconnection cannot be excluded.

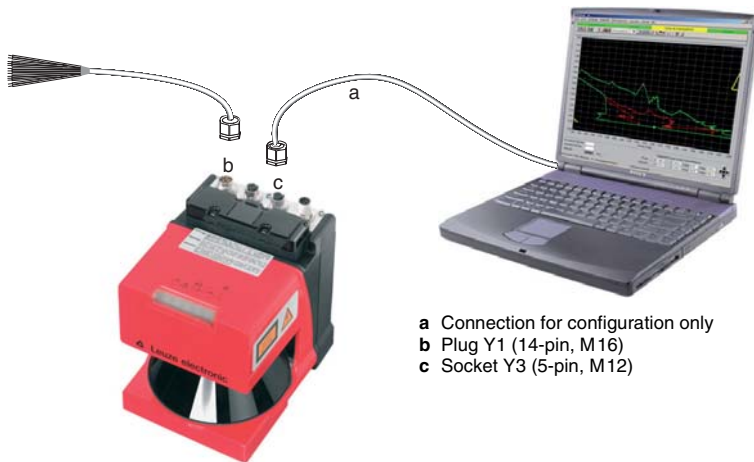

Figure 5.1: Connecting the rotoScan ROD4...plus



Attention!

Should you not need one of the interfaces, close the respective connector with a blank plug. If a connector remains open, the ROD4...plus no longer has degree of protection IP 65.

5.1.1 Connection functions Y1 to Y4

Connection	Connector	Signals
Y1	M 16 plug 14-pin	Logic interface <ul style="list-style-type: none"> • Power supply • Switching outputs/alarm output • Inputs for field pair changeover • Restart/reset input
Y2	M12 socket D-coded 4-pin	Ethernet interface <ul style="list-style-type: none"> • Ethernet measurement data transfer at 10/100Mbit/s • Configuration, measurement data transfer, diagnostics with RODplussoft
Y3	M12 socket 5-pin	rotoScan ROD4...plus <-> PC interface <ul style="list-style-type: none"> • Detection field definition with RODsoft • Configuration, diagnostics with RODplussoft
Y4	M12 plug 8-pin	RS 232/RS 422 interface <ul style="list-style-type: none"> • Factory setting: Measurement data transfer at 115kbit/s • Configuration, measurement data transfer, diagnostics with RODplussoft

Table 5.1: Connections of the ROD4...plus – Y1 to Y4

5.1.2 Connector assignments for connection Y1

	Pin	Signal	Description
	A	U _B	Supply voltage +24VDC
	C	GND	Supply voltage ground
	E	FPS1	Switch to detection field pair 1
	G	FPS2	Switch to detection field pair 2
	J	FPS3	Switch to detection field pair 3
	L	FPS4	Switch to detection field pair 4
	M	Restart	Safe input "restart-disable", reset the ROD4...plus and connection of the restart button
	N	Fn1	Semiconductor output, shutdown on object detection in the near detection field, channel 1.
	O	Fn2	Semiconductor output, shutdown on object detection in the near detection field, channel 2.
	P	ALARM2	Warning and error output.
	R	ALARM1	Output for object detection in the far detection field and for warning messages such as "Window lightly soiled" or "Window heavily soiled" (configurable).
	S	NC	Do not use!
	T	NC	Do not use!
	U	NC	Do not use!

Table 5.2: Pin assignments for connection Y1



Notice!

For interfaces Y1 to Y4, ready-made cables are also available. See "Accessories" on page 36.

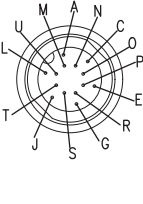
5.1.3 Connector assignments for connection Y2 (Ethernet)

	Pin	Signal	Description
	1	TX+	Data communication, transmission
	3	TX-	Data communication, transmission
	2	RX+	Data communication, reception
	4	RX-	Data communication, reception

Table 5.3: Pin assignments for connection Y2

For an Ethernet connection, you must connect TX+ to TX+, TX- to TX-, RX+ to RX+ and RX- to RX-. The contact assignments on the Y2 M12-socket correspond to the PROFINET standard. The following tables apply for cable fabrication. Alternatively it is possible to use a crossover cable in most applications.

M12	Pin	Signal	Pin	M12
	1	TX+	1	
	3	TX-	3	
	2	RX+	2	
	4	RX-	4	

Table 5.4: Connection M12 to M12 (1:1)

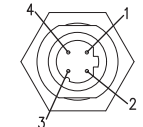
M12	Pin	Signal	Core color	Pin	RJ45, e.g. D-ET1
	1	TX+	Yellow	1	
	3	TX-	Orange	2	
	2	RX+	White	3	
	4	RX-	Blue	6	

Table 5.5: Connection M12 to RJ45 (1:1)

5.1.4 Connector assignments for connection Y3 (service)

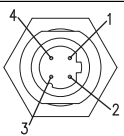
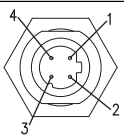
	Pin	Signal	Description
	1	NC	Do not use!
	2	TxD	Data communication, transmission
	3	GND	Data communication, ground
	4	RxD	Data communication, reception
	5	NC	Do not use!

Table 5.6: Pin assignments for connection Y3

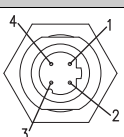
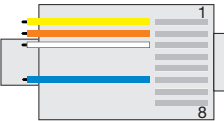
5.1.5 Connector assignments for connection Y4 (RS 232/RS 422)

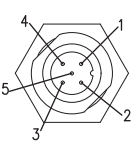

Notice!

If you would like to work with an RS 422 interface, you must connect PIN 6 with PIN 5 (GND) by means of a bridge.

	Pin	Signal	Description
	1	Tx+/TxD	Transmitted data
	2	Tx-	
	3	Rx-	Received data
	4	Rx+ / RxD	
	5	GND/shield	Ground/shielding (to be connected only on the cabinet side with PE)
	6	RS 422	Selection RS 232/RS 422, RS 232: leave PIN 6 open RS 422: bridge to PIN 5!
	7	NC	Do not use!
	8	NC	Do not use!

Table 5.7: Pin assignments for connection Y4

5.2 Functions of connection Y1

5.2.1 Input circuit

There are four connections on the top of the device. A ready-made cable (KB-014-...) is connected at connection Y1 with the 14-pin M16 connector.

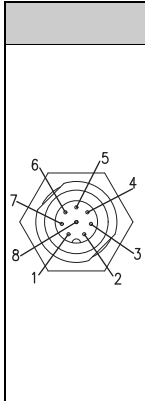
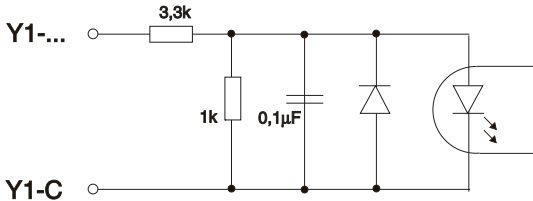

Figure 5.2: Inputs of interface Y1

Inputs FPS1 ... FPS4

With the ROD4...plus it is possible to work with up to four detection field pairs. Use inputs **Y1-E** (FPS1), **Y1-G** (FPS2), **Y1-J** (FPS3) and **Y1-L** (FPS4) to switch between the detection field pairs.

Detection field pairs are activated by applying +24VDC (logic: 1) to the appropriate inputs. If no input is wired, detection field pair 1 is activated.



Attention!

If an **inadmissible signal combination** (e.g. 1-1-1-1) is applied at inputs FPS1 ... FPS4 , a **warning is output at output ALARM2** and **outputs Fn1/Fn2 are switched off**.



Notice!

When switching detection field pairs, first switch on the new detection field pair and then switch off the old detection field pair.

Example of detection field pair switch:

- Detection field pair 1 (Y1-E) is the active, primary detection field.
- Detection field pair 2 is activated by applying the supply voltage +24VDC to input FPS2 (Y1-G).
- **Both** detection field pairs are active in this state!
- Detection field pair 1 (Y1-E) is switched off if the voltage at pin Y1-E is removed.
- Detection field pair 2 (Y1-G) is active in this state.

The following situation would be possible with a DTS application (see figure 5.3):

The vehicle enters an intersection area while detection field pair 1 (I) is switched on (①). To prevent objects from coming into danger, detection field pair 2 (I + II) is switched on before the curve (≠). Afterward, detection field pair 1 is switched off. The vehicle travels around the curve with detection field pair 2 (II) active (≠). Afterward, detection field pair 1 (I + II) is switched back on (≠). Detection field pair 2 is deactivated and the vehicle continues to travel with active detection field pair 1 (I) (≠).

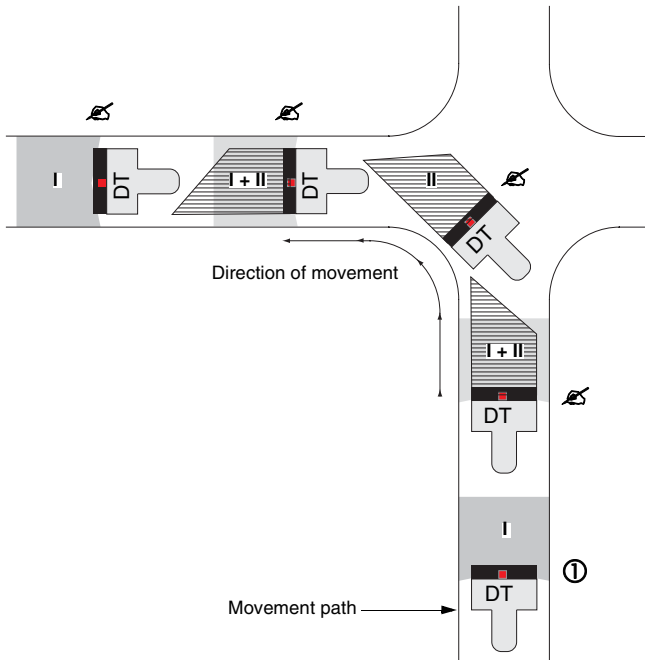

Figure 5.3: Example: Detection field pair switch for a DTS application



Notice!

When configuring the switching on or switching off of detection field pairs, take into account that the ROD4...plus switches over within the response time.



Attention!

If more than two detection field pairs are selected, the ROD4...plus reports a fault at output **ALARM1** (Y1-R) and via the corresponding LED in the display field.

5.2.2 Output circuit

The signal outputs are used to control indicator lamps or relays which indicate the device status. This is switched by a transistor output with open collector set to "active high" (operating voltage).

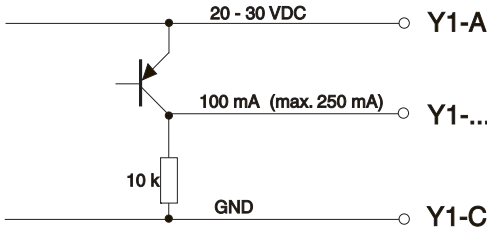

Figure 5.4: Outputs of interface X1

"Fn1" (Y1-N) and "Fn2" (Y1-O)

These two semiconductor outputs report violation of the **near** detection field. Y1-N and Y1-O = "active high" signals that **no** object is located in the **near** detection field. The "low" state signals the detection of an object in the **near** detection field.

"ALARM1" (Y1-R)

This output is configured via the **RODsoft** configuration software.

Y1-P = "active high" signals that the ROD4...plus is ready for operation. The "low" output state signals one of the following states:

1. Possibility: Object detection in the **far** detection field.
2. Possibility: Device warning, e.g light window contamination, etc.
3. Possibility: Object detection in the **far** detection field or device warning, e.g. light window contamination, etc.
4. Possibility: No signalling.
5. Possibility: Device error, e.g. faulty reference measurement or rotational speed deviation



Notice!

A device error output at alarm output "ALARM2" switches all outputs of the ROD4...plus to "low". This means that alarm output "ALARM1" is also on "low" independent of its configuration.

"ALARM2" (Y1-P)

The "low" output state always signals warning and malfunction states, independent of how output "ALARM1" (Y1-R) is configured.

5.2.3 Restart

The RESTART input Y1-M has, depending on operating state, several functions:

- Release of the restart-disable following object detection in the detection field.
- Release of the start disable following a system start.

The functions are activated by applying +24VDC to input Y1-M of an operationally ready ROD4...plus. Outputs Fn1 and Fn2 are switched off in the meantime; the display on the ROD4...plus (LED no. 3) illuminates red. A voltage of +24VDC must be applied to the RESTART input for between 0.12s and 3s.



Notice!

Ensure that the actuation time for the restart input is within the specified times (using a pulse generator if necessary). Malfunctions may otherwise occur.



Attention!

Restart input Y1-M must be connected to an external, permanently mounted button. Y1-M must not be connected to the rest of the control as, under certain conditions, the application of a restart pulse could result in an unintended release.

5.3 Functions of connection Y2

An Ethernet interface is available at connection Y2. It is used for measurement data transfer with the following protocols:

- Binary, ROD4 compatible
- ASCII Remote

It can also be used for configuring the measurement instrumentation with **RODplussoft**.

The Ethernet interface supports the TCP/IP protocol. According to the protocols mentioned above, each measurement data transfer is initiated with a TCP/IP start frame and ended with a TCP/IP stop frame. Supported data transmission rates are: 10/100Mbd

Cable KB ET ... SA is used for connecting the Ethernet interface. On the ROD4...plus end, the cable has a 4-pin D-coded connector; on the other end, the cable is open. If the cable is to be connected to a standard RJ45 network port, it is recommended that the D-ET1 connector be attached to the open cable end.

5.3.1 Y2 default settings

The Ethernet interface is configured ex works as follows:

- IP address: 192.168.60.3
- Subnet mask: 255.255.255.0



Notice!

You can use RODplussoft to change the configuration of interface Y2.

5.4 Functions of connection Y3

An RS 232 interface is available at connection Y3 (5-pin M12 socket). It is used to

- configure the measurement function of the ROD4...plus with **RODplussoft**
- configure the detection function of the ROD4...plus with **RODsoft**
- diagnose errors and perform troubleshooting.

The KB-ROD4 plus... ready-made cable (accessory) is used for configuring the ROD4...plus.

5.4.1 Y3 default settings

Interface Y3 is configured ex works as follows:

- Baud rate: 57.6kBd
- Data bits: 8
- Stop bits: 1
- Parity: none



Notice!

These settings cannot be changed.

5.5 Functions of connection Y4

At connection Y4 (8-pin M12 plug), either an RS 232 or RS 422 interface is available. It is used for measurement data transfer with the following protocols:

- Binary, ROD4 compatible
- ASCII Remote

It can also be used for configuring the measurement instrumentation with **RODplussoft**.

According to the protocols mentioned above, in the default setting each measurement data transfer is initiated with an STX command and ended with an ETX command.

The K-D M12A-8P... ready-made cable (accessory) is used for measurement data transfer with an RS 232/RS 422 interface.

5.5.1 Y4 default settings

The PC interface is configured ex works as follows:

- Baud rate: 115.2kBd
- Data bits: 8
- Stop bits: 1
- Parity: none



Notice!

*Only the transmission rate of the interface can be changed using **RODplussoft**.*

5.6 Connection

5.6.1 Electrical supply

The ROD4...plus requires a DC voltage of +24VDC for its electrical supply. The power consumption is

- max 20 W for the ROD4 plus, ROD4-50 plus (without heating)
- max 75 W for the ROD4-08 plus, ROD4-56 plus, ROD4-58 plus (with heating)

plus the load at the outputs (max. 20W).

The power supply must be fed in via an **external fuse** (e.g., in a switch cabinet): **2.5 A semi time-lag** (ROD4 plus, ROD4-50 plus) or **4 A semi time-lag** (ROD4-08 plus, ROD4-56 plus, ROD4-58 plus). Furthermore, upstream of the safeguard in the supply line, a constant current of 2.5 A or 4 A, respectively, is to be provided to ensure that the fuse can be tripped in the case of failure.

5.6.2 Button for restarting (only ROD4 plus and ROD4-08 plus)



Attention!

Any additionally used switching components (e.g. button for restarting) must be permanently mounted.

- Loosely position the button at the intended position.
- Switch on the voltage supply of the ROD4...plus which has been configured for the application.
- Activate one of the detection field pairs FPS1 to FPS4 by applying +24V to E, G, J, or L.
- Position an object in the **near** detection field of the previously activated detection field pair. The following status indicator appears upon detection of the object by the ROD4...plus (see also chapter 10.2):



Red LED illuminated:
outputs Fn1 and Fn2 disabled

Yellow LED with continuous light:
restart-disable active

- Now actuate the restart button and observe the left, green LED. If this LED illuminates, you are no longer in the **near** detection field and the location of the button is suitable. If the LED does not illuminate, there are still objects located within the **near** detection field. In this case, change the location of the button and perform the test again.

5.7 Integration in the control system (only ROD4 plus and ROD4-08 plus)

The two following examples illustrate possibilities for integrating into a control system. After connecting the operating voltage at PIN Y1-A (+U_B) to PIN Y1-C (GND) and activating at least one of the detection field pairs (Y1-E, Y1-G, Y1-J or Y1-L), the device is ready for operation.

5.7.1 Connection example 1: without detection field pair switch

Integrating the ROD4...plus with discrete external wiring with relay or contactor without detection field pair switch:

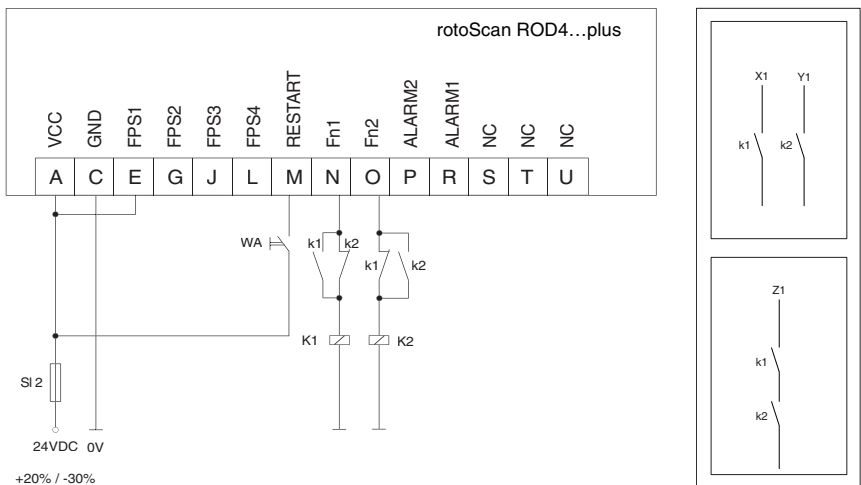

Figure 5.5: Connection example without detection field pair switch

With this connection example, the restart-disable is realised by means of the command device "WA" connected at the RESTART input (Y1-M). The device must, in this case, be configured with the software in such a way that the operating mode "with restart-disable" is active.

Detection field pair switch is not provided in this example. For this purpose, directly connect FPS1 (Y1-E) to the operating voltage VCC. The relays K1 and K2 used here have overlapping contacts (make before break) and are operated directly at the two semiconductor outputs Fn1 (Y1-N) and Fn2 (Y1-O).

The two semiconductor outputs possess an internal electronic current limit and are protected in the event of errors by fuse SI 2.

5.7.2 Connection example 2: with detection field pair switch

Integrating the ROD4...plus with discrete external wiring with relay or contactor with detection field pair switch:

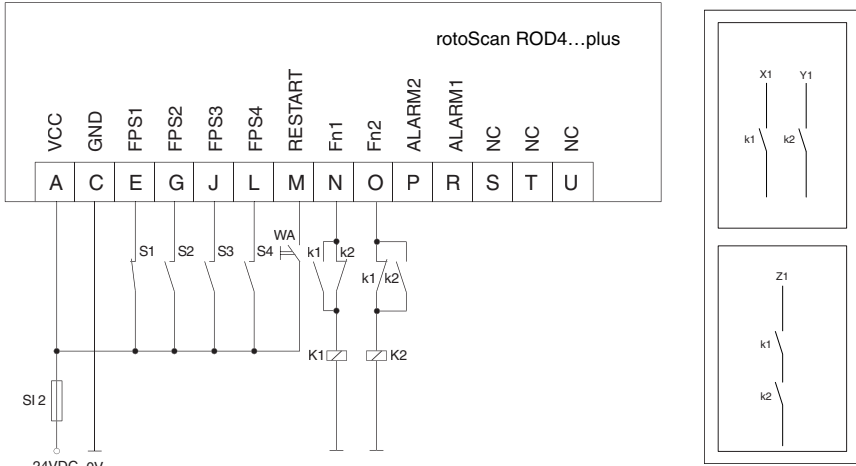

Figure 5.6: Connection example with detection field pair switch

In this example, a detection field pair switch of 4 detection field contours is possible via inputs FPS1 (Y1-E), FPS2 (Y1-G), FPS3 (Y1-J) and FPS4 (Y1-L) (one near and one far contour for each). The restart-disable and contactor monitoring are realised via the RESTART input.

The ROD4...plus is operated in this case in the operating mode "with restart-disable". The currently active, violated detection field is released by the command device "WA". The relays K1 and K2 used here have overlapping contacts (make before break) and are operated directly at the two secure semiconductor outputs Fn1 (Y1-N) and Fn2 (Y1-O).

6 Start-up

By means of appropriate configuration with the aid of the **RODplussoft** (for the measurement function) or **RODsoft** (for the detection/switching function) configuration software, the user can adapt the ROD4...plus to the given application conditions.

6.1 Hardware and software requirements

First steps with the device require the basis ROD4...plus unit, an interface cable and a PC. For the voltage supply, a power supply unit possessing the characteristics described in chapter "Technical data" on page 40 is required.

The PC used should meet the following requirements:

- Intel® processor at Pentium® level or faster (or compatible models, e.g. AMD®)
- At least 512 MB RAM
- CD drive
- Hard disk with at least 150 MB available memory.
- RS 232 interface for configuring the ROD4...plus
- Ethernet interface or, alternatively, the RS 232 / RS 422 for measurement data transfer
- Microsoft® Windows 2000/XP SP2/7/8
- Microsoft® .NET Framework 2.0 SP1

The **RODplussoft** or **RODsoft** configuration software can be found on the supplied CD. To install, follow the instructions in the respective readme files, which can likewise be found on the supplied CD.

6.2 Device configuration

If you would only like to configure the measurement functions of the ROD4...plus, it is sufficient to install **RODplussoft**.

If you would like to configure the detection functions of the ROD4...plus, you must install **RODplussoft** and **RODsoft**. **RODsoft** is called up via **RODplussoft**. The use of interface **Y3** for device configuration is a prerequisite for using **RODsoft**.



Notice!

The programs are described in the manuals, which can likewise be found on the supplied CD as PDF files.

6.2.1 Configuring measurement applications with RODplussoft

Commissioning procedure:

- Install the **RODplussoft** configuration software on the PC (setup.exe)
- Connect the ROD4...plus to the PC via the KB-ROD4 plus... cable
- Start **RODplussoft**
- Define and configure interfaces for configuration and process data.



Notice!

*Before commissioning the device, you must adjust the device parameters and the measurement function for your application. To do this, configure the transmission parameters and measurement segments using the user manual for the **RODplussoft** software.*

6.2.2 Selecting the measurement data protocol

The measurement data can be transferred using 2 different protocols.

A detailed description of protocols and software can be found in document "ROD4 plus software and protocol description". The individual protocols are described briefly in the following.

ROD4-compatible binary protocol

The **ROD4-compatible** binary protocol is preset ex-works as the protocol for the ROD4...plus. Its structure is fixed and cannot be modified by the user. It is designed for simple and fast measurement tasks and is also used for configuring the switching function of the ROD4...plus.

The protocol is very fast and efficient due to the fact that a measurement value is transferred with 2 bytes. It can be used to define a measurement segment with start and stop angle and the angular resolution (angular separation of two successive measurements in the segment).

All configuration data which are transferred to the ROD4...plus using this protocol are stored in the parameter memory of the ROD4...plus and are retained even after the ROD4 is switched off.

ASCII Remote

The **ASCII Remote** protocol is used to configure the ROD4...plus using so-called online commands via a terminal program. RODplussoft offers one such terminal window: the Toolbox.

The advantage of the ASCII format over the binary protocol is that it can be read directly on the PC without any additional software. This protocol is, however, slower. As a result, more data must be transferred.

Using the ASCII-Remote protocol, up to 12 mutually independent measurement segments can be defined and the measurement task can be continuously changed during operation.

As a result, the control can e.g. be programmed for a driverless transportation system in such a way that a rough scan of the entire area in front of the ROD4...plus is performed during normal operation. Upon detection of an obstacle, a new measurement segment can

be defined around the obstacle. Measurement is then performed with the maximum possible accuracy within this area.

In addition, it is possible to filter the measurement values prior to transfer and, thus, only transfer measurement values which lie in a freely configurable coordinate range.

Furthermore, instead of individual coordinate values, it is possible to transfer only the extreme values within the individual measurement segments.



Notice!

The transferred configuration data are stored in the ROD4...plus. They are, however, stored in volatile memory, i.e. they are lost when the ROD4...plus is switched off.

6.2.3 Defining detection fields with RODsoft (only ROD4 plus and ROD4-08 plus)

Commissioning procedure:

- Install the **RODsoft** configuration software on the PC (setup.exe)
- Connect the ROD4...plus to the PC via the KB-ROD4 plus... cable
- Use the **Start RODsoft** menu option to start **RODsoft** from within **RODplussoft**
- Enter password "**ROD4LE**" in level "authorised customer"

Short description:

The detection field can then be displayed under "Display measurement contour". Under "ROD4 configuration" the response times, the detection field switches and other parameters are defined. To configure the detection fields, select the "Define detection areas" field. Error codes and other information are contained in the ROD4 system data. A detailed description can be found in the user manual for the **RODsoft** configuration software.

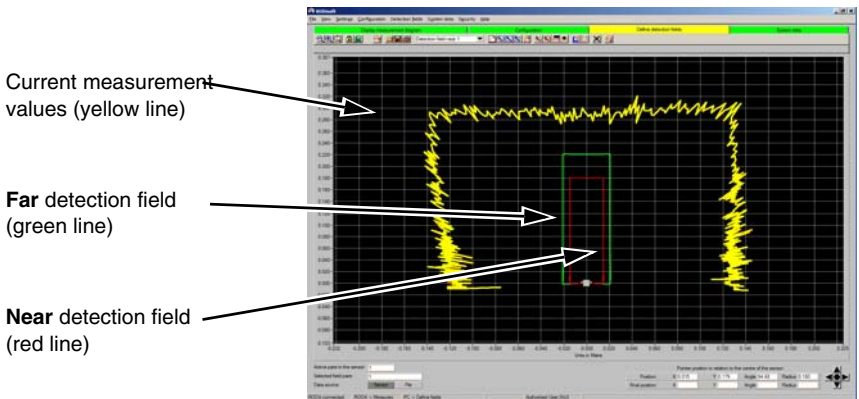

Figure 6.1: User interface of the **RODsoft** configuration software

**Notice!**

*Before commissioning the device, you must adjust the device parameters and the detection fields for your application. To do this, configure the ROD4...plus using the **RODsoft** software user manual so that the detection fields are optimised for the monitoring task.*

6.3 Screwing down and aligning the device

The ROD4...plus is to be mounted and aligned as described in chapter 4.

6.4 Switch on the device

Once the device is installed, the required device parameters set and the detection fields defined, the ROD4...plus can be put into operation.

After you have switched on the voltage supply of the ROD4...plus, illumination of the red LED on the interface box indicates the operational readiness of the ROD4...plus.

7 Testing and maintenance

7.1 Test

If detection fields are defined, the response of the detection fields should be monitored to ensure the availability.

7.2 Cleaning

The front cover should be cleaned at regular intervals (application dependent) with a soft cloth and commercially available, non-aggressive glass cleaner.



Attention!

Do not use solvents or cleaning agents containing acetone. Use of improper cleaning agents can damage the housing window.

If window monitoring continues to report a soiled cover even after cleaning, it must be replaced with a new front cover.

8 Delivery contents and accessories

8.1 Type overview

Part no.	Type designation	Remark
50106481	ROD4 plus	For object detection / object measurement, scanning rate 25scans/s
50106480	ROD4-08 plus	For object detection / object measurement, scanning rate 25scans/s, with heating, dust-insensitive
50113226	ROD4-50 plus	For object measurement, scanning rate 50scans/s
50129795	ROD4-56 plus	For object measurement, scanning rate 50scans/s, with heating
50113225	ROD4-58 plus	For object measurement, scanning rate 50scans/s with heating, dust-insensitive

8.2 Accessories

The following **accessories** are available:

Part no.	Type designation	Remark
50106976	KB-014S-5000-14	Connection cable M16 for ROD4, angular M16 socket on one end, 14-pin, cable length 5m, shielded
50106977	KB-014S-10000-14	Connection cable M16 for ROD4, angular M16 socket on one end, 14-pin, cable length 10m, shielded
50109881	KB ET-5000-SA-RJ45	Connection cable M12 Ethernet, PUR, M12 connector, D-coded/RJ-45 connector, cable length 5m
50109882	KB ET-10000-SA-RJ45	Connection cable M12 Ethernet, PUR, M12 connector, D-coded/RJ-45 connector, cable length 10m
50106740	KB ET-5000-SA	Connection cable M12 Ethernet, PUR, M12 connector, D-coded/open cable end, 4-pin, cable length 5m
50106741	KB ET-10000-SA	Connection cable M12 Ethernet, PUR, M12 connector, D-coded/open cable end, 4-pin, cable length 10m
50106881	KB-ROD4plus-5000	Configuration cable for ROD4, axial M12 connector/Sub-D socket (9-pin), 4-pin, cable length 5m
50106906	KB-ROD4plus-10000	Configuration cable for ROD4, axial M12 connector/Sub-D socket (9-pin), 4-pin, cable length 10m
50104590	K-D M12A-8P-5m-PUR	Connection cable M12 RS 232/RS 422, axial M12 socket/open cable end, 8-pin, cable length 5m
50106882	K-D M12A-8P-10m-PUR	Connection cable M12 RS 232/RS 422, axial M12 socket/open cable end, 8-pin, cable length 10m
50108991	D-ET1	RJ45 connector for Industrial Ethernet, freely configurable
50038066	BT ROD4	Mounting system for ROD4

8.2.1 Pin assignments KB-014S-...-14

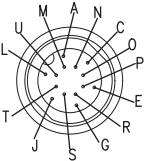
M16 socket	Pin	Signal	Core color
	A	U _B	Red
	C	GND	Blue
	E	FPS1	Pink
	G	FPS2	Gray
	J	FPS3	Yellow
	L	FPS4	Green
	M	Restart	Brown
	N	Fn1	White
	O	Fn2	Violet
	P	ALARM2	Black
	R	ALARM1	White-green
	S	NC	Red-blue
	T	NC	Brown-green
	U	NC	Gray-pink

8.2.2 KB-ROD4plus... pin assignments

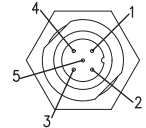
M12 plug	Pin	Signal	Core color	PIN on Sub-D socket
	1	NC	Brown	-
	2	TxD	White	2
	3	GND	Blue	5
	4	RxD	Black	3
	5	NC	Gray	-

8.2.3 Pin assignment KB ET-...-SA-RJ45 (crossover cable)

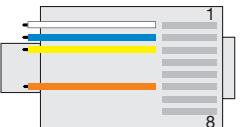
M12 plug	Pin	Signal	Core color	Pin	RJ45
	1	TX+	Yellow	3	
	3	TX-	Orange	6	
	2	RX+	White	1	
	4	RX-	Blue	2	

8.2.4 Pin assignments KB ET...-SA

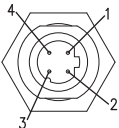
M12 plug	Pin	Signal	Core color
	1	TX+	Yellow
	3	TX-	Orange
	2	RX+	White
	4	RX-	Blue

8.2.5 Pin assignments K-D M12A-8P...

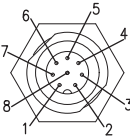
M12 socket	Pin	Signal	Core color
	1	Tx+/TxD	White
	2	Tx-	Brown
	3	Rx-	Green
	4	Rx+ / RxD	Yellow
	5	GND/shield	Gray
	6	RS 422	Pink
	7	NC	Blue
	8	NC	Red

8.2.6 BT ROD4 mounting system

The ROD4...plus can be fastened using the holes on the rear of the device. No mounting kit is necessary in this case. It is, however, recommended that the ROD4...plus be mounted with the aid of the BT ROD4 mounting system. The advantage of this mounting variant lies in the exchangeability of the device. The device can, in this way, be removed from the mounting system and returned at a later time without readjusting the device.

With the aid of the BT-ROD4 mounting system, pitches of maximum 8° downward or upward are possible. In addition, the mounting kit allows lateral inclinations of up to ±4°.

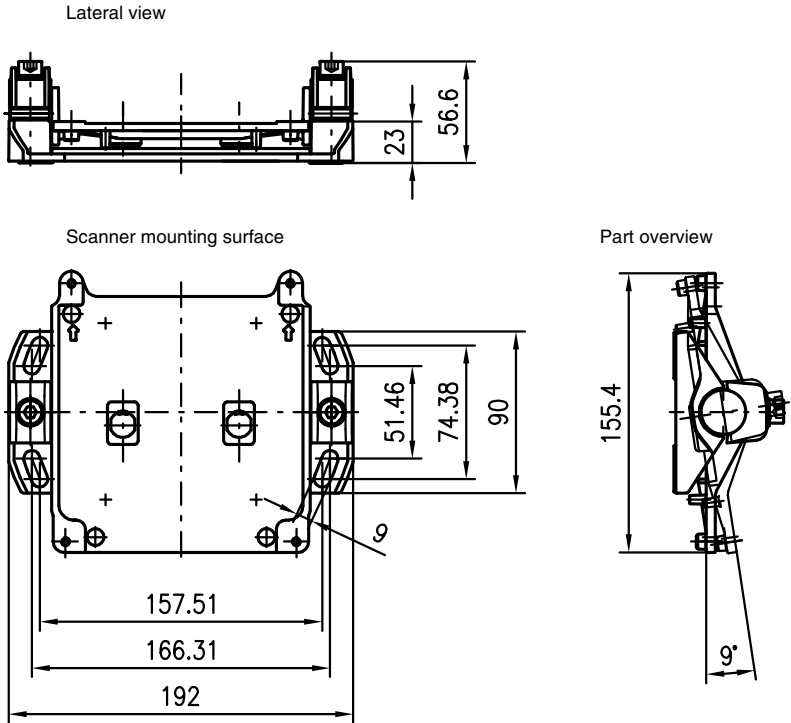

All dimensions in mm

Figure 8.1: Dimensioned drawing BT ROD4

9 Technical data

9.1 Object measurement

Object measurement	
Detection range	ROD4 plus, ROD4-50 plus, ROD4-56 plus: 0 ... 65m ROD4-08 plus, ROD4-58 plus: 0 ... 25m
Luminosity coefficient	see figure 9.1
Object size	see figure 9.1
Output	serial interface RS 232, RS 422
Distance resolution	5mm
Angular resolution	0.36°
Repeatability	± 15mm

Table 9.1: Technical data - object measurement

9.2 Detection field data (only ROD4 plus and ROD4-08 plus)

Near detection field	
Radius of near detection field	ROD4 plus: 0 ... 30m ¹⁾
Reflectivity	ROD4 plus: from min. 1.8% (flat black) ROD4-08 plus: from min. 6%
Object size	see figure 9.1
Response time	at least 40ms (corresponds to 1 scan)
Number of detection field pairs	4 (selectable via switching inputs)
Output	two PNP transistor outputs, 24V/250mA
Start-up	the start-up testing and start disable are configured separately.

Far detection field	
Radius of far detection field	ROD4 plus: 0 ... 50m ¹⁾
Reflectivity	ROD4 plus: from min. 1.8% (flat black) ROD4-08 plus: from min. 6%
Object size	see figure 9.1
Response time	at least 40ms (corresponds to 1 scan)
Number of detection field pairs	4 (selectable via switching inputs)
Output	one PNP transistor output, max. 100mA

1) Particularly in the far range, the ROD4-08 plus only detects large objects and objects with high diffuse reflection

Table 9.2: Technical data - detection fields

9.3 Electrical data

Power supply	
Voltage supply ¹⁾	+24VDC +20% / -30%
Overcurrent protection	via fuse 2.5A (4A with heating) semi time-lag in the switch cabinet
Current consumption	approx. 1A (approx. 2.5A with heating)
Power consumption	24 ... 75W at 24VDC
Overvoltage protection	overvoltage protection with protected limit stop
Voltage dips	acc. to EN 61496-1 (VDE 0113, part 201)

- 1) Protective Extra Low Voltage (PELV) - protective extra-low voltage with reliable disconnection.
For UL applications: only for use in class 2 circuits according to NEC.

Inputs (at Y1)	
Restart/Reset	command device for operating mode with restart-disable and/or device reset; dynamically monitored, 24VDC optically decoupled (activate for 0.12 ... 3s)
Detection field changeover	selection between max. 4 detection field pairs via four control lines with internal monitoring, 24VDC opto-decoupled

Interfaces ¹⁾	
Y2 Ethernet	10/100 MBd, TCP/IP peer-to-peer
Y3 Service RS 232	57.6kBd, 8 data bits, no parity, 1 stop bit, setting permanently stored
Y4 RS 232/422	RS 232/422 reversible, factory setting 115kBd, 8 data bits, no parity, 1 stop bit

- 1) With **RODplussoft**, all three interfaces can be used for configuration. Measurement data can be transferred either via Y2 or Y4.
RODsoft can only communicate with the ROD4...plus via interface Y3.

Outputs (at Y1)	
For near detection field (Fn1, Fn2)	2x semiconductor output, PNP max. 250mA short-circuit monitored, overcurrent protected, load must demonstrate lowpass characteristics, limit frequency $f_g \leq 1 \text{ kHz}$
For far detection field / soiling (ALARM1)	PNP transistor output, max. 100mA, configurable
For far detection field / warning and error output (ALARM2)	PNP transistor output, max. 100mA, not configurable

Table 9.3: Technical data - electrical data

9.4 Software

Object measurement	
Configuration software	configuration software "RODplussoft" under Windows 2000/XP/7/8

Object detection	
Configuration software	configuration software "RODsoft" under Windows 2000/XP/7/8

Table 9.4: Technical data - software

9.5 Optical data

Optical properties	
Scanning angle	max. 190°
Angular resolution	0.36°
Scanning rate	ROD4 plus: 25scans/s or 40ms/scan
	ROD4-08 plus:
	ROD4-50 plus: 50scans/s or 20ms/scan
	ROD4-56 plus:
ROD4-58 plus	
Laser class	1 acc. to IEC 60825-1:2007
Wavelength	905nm (infrared light)
Impulse duration	3ns
Max. output power (peak)	15W

Optical properties	
Beam divergence	2 mrad
Time basis	100s
Beam dimensions	see diagram (figure 9.2)

Table 9.5: Technical data - optical data

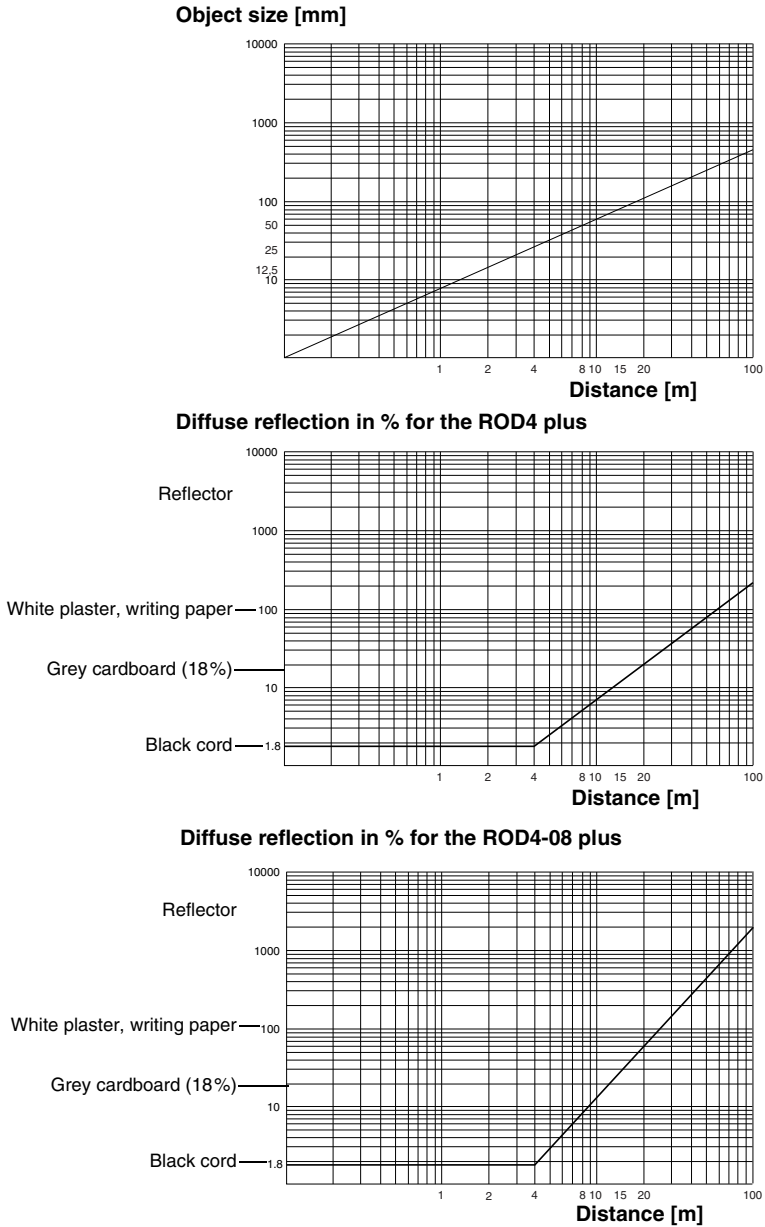

Figure 9.1: Object size/diffuse reflection as a function of distance for the ROD4... plus

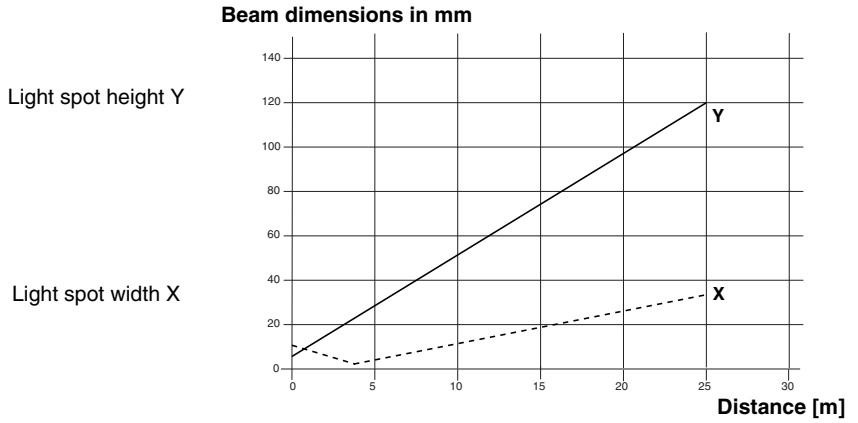

Figure 9.2: Typical beam dimensions with the ROD4...plus

9.6 Environmental data

Environmental and material data	
Degree of protection	IP 65 acc. to IEC 60529
Contact protection	all-insulated, safety class 2
Operating temperature	0°C ... +50°C, with heating -20°C ... +50°C
Storage temperature	-20°C ... +60°C
Humidity	DIN 40040 Table 10, code letter E (moderately dry)
Dimensions	141 x 167 x 168 (W x H x D) in mm
Distance from scanning plane to bottom edge of housing	48.75 mm
Connection	4 connectors
Cable length	max. 50m with conductor cross-section 0.5 mm ² (valid for Y1, Y2, and Y4 as RS 422)
Housing	diecast aluminum, plastic
Weight	approx. 2.3 kg
Vibrating stress	acc. to IEC 60068 part 2 - 6, 10 ... 55 Hz max. 5 G
Continuous shock	acc. to IEC 60068 part 2 - 29, 10 G, 16 ms
Interference rejection	as per DIN EN 61496-3 (in accordance with the requirements for type 4) as well as per DIN 40839-1/3 test impulse 1, 2, 3a, 3b and 5 (no application for vehicles with combustion motors)
Rotating mirror drive	brushless DC motor
Rotating mirror bearings	maintenance-free ball bearing

Table 9.6: Technical data - environmental data

9.7 Dimensioned drawing ROD4...plus

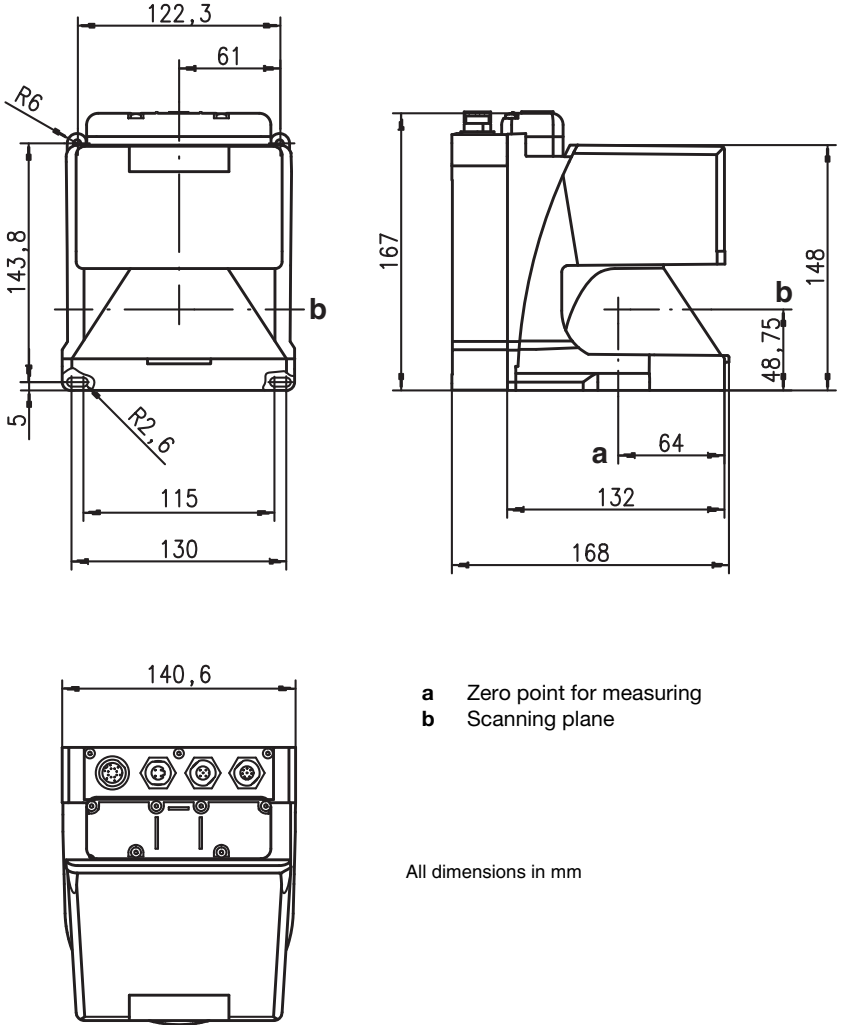

Figure 9.3: Dimensioned drawing ROD4...plus

10 Status messages, errors and error rectification

10.1 Ethernet status indicator

The state of the Ethernet connection can be read from three LEDs located on top of the connector housing. A cover protects the LEDs from contamination and guarantees degree of protection IP 65. When in a voltage-free state, the LEDs are hidden from view by this cover.

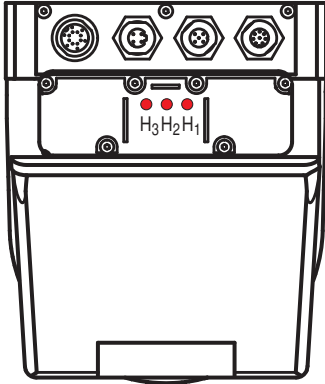

Figure 10.1: Ethernet status indicator

LED	Color	Function / Meaning
H ₁	Red	Ethernet system ready
H ₂	Red	Ethernet connection present
H ₃	Red	Ethernet data transmission active

10.2 ROD4...plus status indicator

The status of the ROD4...plus can be read using the five LEDs on the front side of the device. A white cover protects the LEDs from contamination and guarantees degree of protection IP 65. When in a voltage-free state, the LEDs are hidden from view by this cover.

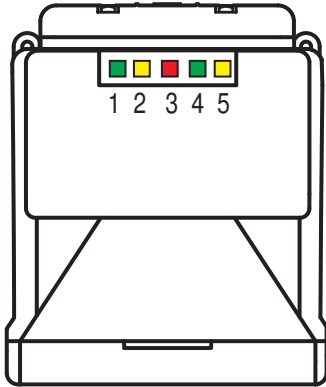

Figure 10.2: ROD4...plus status indicator

LED	Color	Function / Meaning
1	Green	Sensor functions active, near detection field is free
2	Yellow	• Continuous light (CL): far detection field is occupied
3	Red	Near detection field is occupied, Fn outputs are switched off
4	Green	Near detection field is free, Fn outputs are active
5	Yellow	• Slowly flashing (SF) at approx. 1 Hz:warning message • Flashing fast (FF) at approx. 4 Hz:error message • Continuous light (CL):restart-disable locked

10.2.1 Status displays



Notice!

The rotoScan ROD4...plus outputs two different types of messages at output "ALARM1":
Warning message - Information for the user indicating that a non-critical danger area (e.g. window contamination) has been detected in the device.

Error message - System has detected a critical device error and switches off semiconductor outputs Fn1 and Fn2.







LED	Status
	<ul style="list-style-type: none"> Near detection field is free, Fn outputs (Y1-N, Y1-O) are enabled
	<ul style="list-style-type: none"> Near detection field is free, Fn outputs (Y1-N, Y1-O) are enabled, Far detection field is occupied Output Y1-R "ALARM1" is enabled
 SF	<ul style="list-style-type: none"> Near detection field is free, Fn outputs (Y1-N, Y1-O) are enabled, Warning message due to e.g. soiled front cover <p>SF = slow flashing of the yellow LED</p>
 DL	<ul style="list-style-type: none"> Near detection field is occupied, Fn outputs (Y1-N, Y1-O) are disabled, Restart-disable is active <p>CL = yellow LED continuously illuminated</p>
 DL	<ul style="list-style-type: none"> Near detection field is free, Fn outputs (Y1-N, Y1-O) are disabled, Restart-disable is active <p>CL = yellow LED continuously illuminated</p>
 SB	<ul style="list-style-type: none"> Near detection field is occupied, Fn outputs (Y1-N, Y1-O) are disabled, Output "ALARM1" (Y1-R) is enabled <p>FF = fast flashing of the yellow LED</p>

Table 10.1: Status displays on the rotoScan ROD4...plus

10.3 Diagnostic codes and causes

All errors that occur in the ROD4...plus are stored in the error list in the device. You can only call up this list with the **RODsoft** software. On the toolbar, click  or select **System data** → **Load diagnostic data from scanner** on the menu bar.

The error messages from the last 8 events are documented. This first memory slot always contains the most recent error message.

Listed in the following table are all errors together with corresponding troubleshooting notices:

Code	Description	No	Error description
102	Command processing, processing of messages	2	Data transmission error on the configuration interface
103	Control of command processing	2	Data transmission error on the configuration interface
104	Command processing, processing of the configuration	2	Data transmission error on the configuration interface
105	Command processing, generation of output messages	6	Function, access, command not permitted at currently selected authority level
201	Processing of the receive protocol	4	Too much data transferred via the configuration interface; message overwritten by new message
302	Processing of the transmit protocol	2	Data displayed for inspection not acknowledged quickly enough
306	Output of measurement values	5	Previous message not output completely
801	Event processing	2	Event memory cannot be read, internal defect
805	Processing the command for the event memory	6	Event memory cannot be transferred, data transmission error at the configuration interface
1002	Motor control during initialisation	1	Motor does not reach nominal rotational speed after start-up; internal defect
1002	Motor control during initialisation	2	Motor speed not constant after start-up; internal defect
1003	Motor control during initialisation	1	Motor does not reach nominal rotational speed after start-up; internal defect
1003	Motor control during initialisation	2	Motor speed not constant after start-up; internal defect
1003	Motor control during initialisation	3	Motor speed not constant after start-up; time-out
1110	Test of the switching outputs	4	Switching outputs Fn1/Fn2 have a state other than that which is expected by the ROD4...plus; possible wiring or control error
1110	Test of the switching outputs	5	Switching output Fn1/Fn2 does not switch off
1110	Test of the switching outputs	6	Switching output Fn1/Fn2 does not switch on
1111	Short-circuit test of the switching outputs	7	A switching output Fn1/Fn2 is short circuited with ground

Table 10.2:ROD4...plus - Diagnostic codes and causes

Code	Description	No	Error description
1111	Short-circuit test of the switching outputs	8	A switching output Fn1/Fn2 is short circuited with Vcc
1606	Rotational speed monitoring	4	Rotational speed deviation; zero pulse was not correctly detected; internal defect
1607	Monitoring the duration of a scan	5	Rotational speed deviation; motor not at nominal rotational speed
1608	Rotational speed monitoring	8	Motor speed not constant during operation
1608	Rotational speed monitoring	9	Motor speed not constant during operation
1608	Rotational speed monitoring	10	Motor speed not constant during operation
1705	Processing of the window-monitoring photoelectric sensor data	2	Signal from photoelectric sensor of the front-cover monitor above upper limit; liquid media on front cover
1906	Test of the external watchdog	1	Watchdog does not release the Fn outputs; possible wiring or control error
1906	Test of the external watchdog	2	Watchdog does not release the Fn outputs; internal defect
1906	Test of the external watchdog	5	Switching outputs Fn1/Fn2 have a state other than that which is expected by the ROD4...plus; possible wiring or control error
1906	Test of the external watchdog	6	Watchdog does not switch off the shut-down path for the laser; internal defect
1907	Test of the external watchdog	4	Event detected by watchdog; watchdog has switched off (rotational speed deviation); possible rotation of the ROD4...plus housing
1907	Test of the external watchdog	7	Event detected by watchdog; watchdog has switched off (rotational speed deviation); possible rotation of the ROD4...plus housing
2002	Processing of the parameter command	12	Data displayed for inspection not acknowledged quickly enough
2007	Check of received parameter data	18	Date of the currently transferred detection field is older than the date of the detection field in the ROD4...plus
2201	Field monitoring	5	Number of measurements in the scan too small due to rotational speed deviation of the motor or switching off of the watchdog; internal fuse defective
2302	Control of software execution	1	Error occurred during ROD4...plus start-up, secondary error

Table 10.2:ROD4...plus - Diagnostic codes and causes

Code	Description	No	Error description
2401	Reference measurement on the dark reference element	10	No distance value can be calculated for reference measurement; glare from other light sources (905nm) or rotational speed deviation
2401	Reference measurement on the dark reference element	13	No distance value can be calculated for reference measurement; dust in device because connector housing or dummy cap not screwed down
2402	Reference measurement on the light reference element	10	No distance value can be calculated for reference measurement; glare from other light sources (905nm) or rotational speed deviation
2701	Processing of messages for system diagnostics	1	Invalid diagnostic command received, software incompatible with firmware
2702	Processing of requests for diagnostic data	3	Invalid diagnostic value requested, software incompatible with firmware
2800	Processing of the inputs for detection field switching	2	2 detection fields active for longer than 1 s
2800	Processing of the inputs for detection field switching	3	The detection field switching which occurred does not match the preset which was programmed in the ROD4...plus
2800	Processing of the inputs for detection field switching	4	More than 2 detection fields selected during operation
2800	Processing of the inputs for detection field switching	6	Unusable data or inadequate data quality for detection field activation
2801	Test of the inputs for detection field switching	1	Error while testing the inputs for detection field switching; internal defect
2802	Initialisation of detection field changeover	3	The detection field activation which occurred does not match the preset which was programmed in the ROD4...plus
2802	Initialisation of detection field changeover	4	More than 2 detection fields selected during power-on
2802	Initialisation of detection field changeover	6	Unusable data or inadequate data quality for detection field activation
2802	Initialisation of detection field changeover	8	No detection field activated during start-up of the ROD4...plus
3016	Monitoring of the access authorisation with one-time password	11	Confirmed single password has been entered incorrectly

Table 10.2:ROD4...plus - Diagnostic codes and causes

11 Appendix

11.1 Terms and abbreviations ROD4...plus

ALARM1

Configurable output for displaying the violation of detection fields and for various fault and warning messages.

ALARM2

Output for signalling fault and warning messages.

Working range

The working range of the ROD4...plus (190° - from -5.04° to 185.04°) is divided into 0.36° angular segments (corresponds to 529 measurement values). See "Working range and angular resolution" on page 10.

Near detection field

Max. detection range 30m, object detection within the **near** detection field affects outputs Fn1 (pin Y1-N) and Fn2 (pin Y1-O). The **near** detection field is represented in the user interface of the **RODsoft** configuration software by the colour red.

Fn

Short version of the term **near detection field**.

Far detection field

max. detection range 50m (25m for ROD4-08plus), object detection within the **far** detection field affects output ALARM (pin Y1-P) depending on the configuration. The **far** detection field is represented in the user interface of the **RODsoft** configuration software by the colour green.

Ff

Short version of the term **far detection field**.

FP

Field pair, detection field pair;

The configuration software can be used to configure a total of 4 field pairs in the ROD4...plus, each with 2 detection fields (**near** and **far**).

FPS

Field pair changeover.

FPS1

Field pair switch to field pair 1.

Measurement segment

Area defined by start angle and stop angle whose measurement values are transmitted by the ROD4...plus.

Angular segment

The working range of the ROD4...plus is divided into 529 angular segments. An angular segment corresponds to 0.36° . One measurement value is transmitted per angular segment.